

4 x Analog circuit 0-10V / 0-20mA

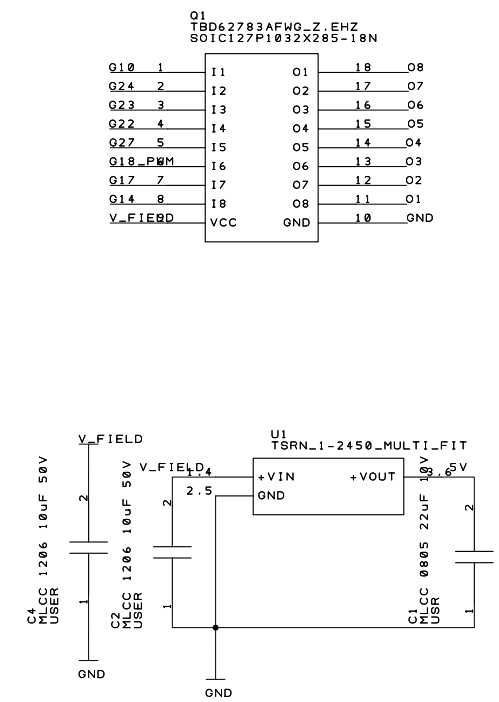

Q1 TSD62783AFWG_Z_EHZ SOIC127P1032X205-18N			
Q10_1	11	01	18_08
Q24_2	12	02	17_07
Q23_3	13	03	16_06
Q22_4	14	04	15_05
Q27_5	15	05	14_04
Q18_PWM	16	06	13_03
Q17_7	17	07	12_02
Q14_8	18	08	11_01
V_FIERD	VCC	GND	10_GND

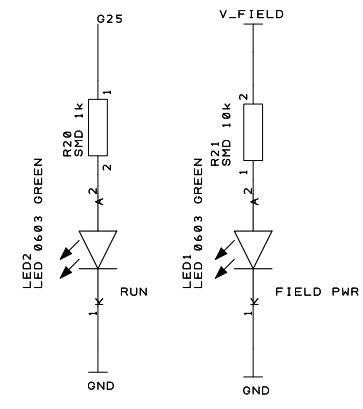
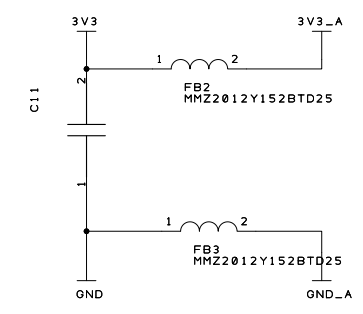
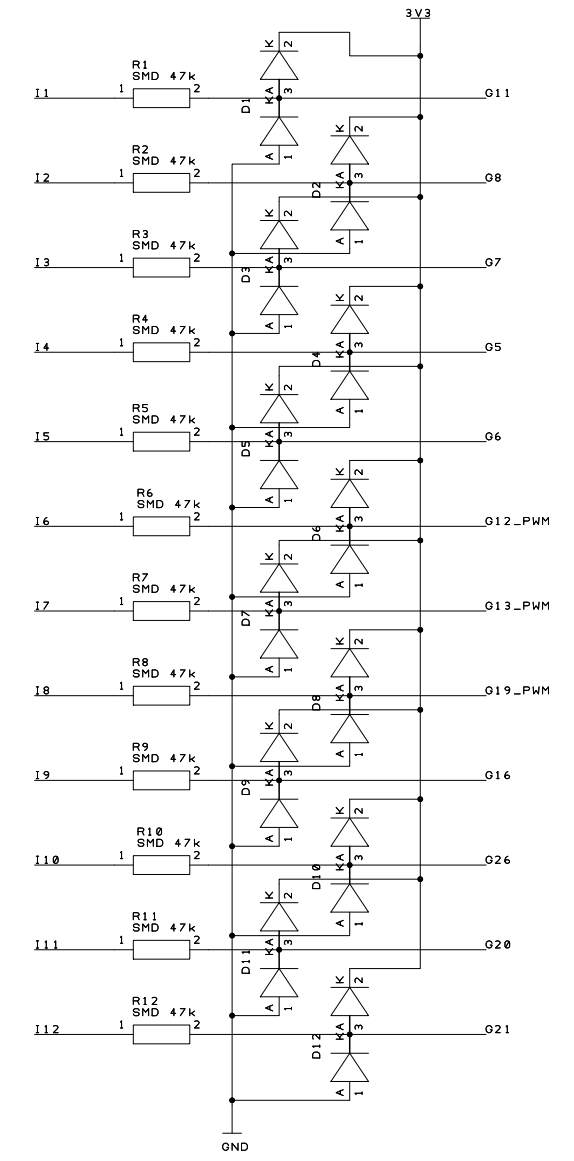
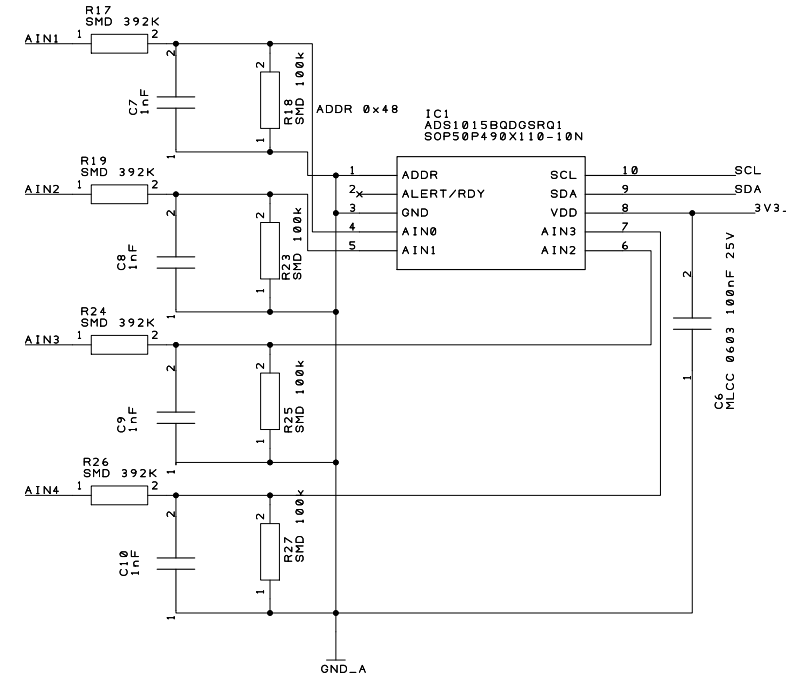